

SAW BOXES

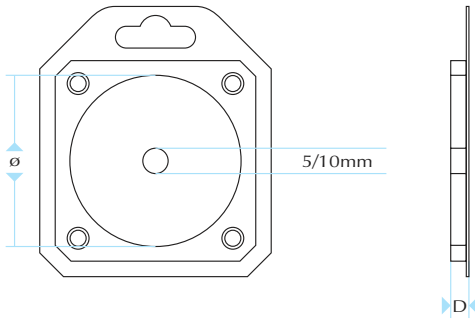

SAW BOX REFERENCE NO.	SAW BOX DIMENSIONS			SAW DIAMETERS	CARTON QUANTITY
	DIAMETER Ø1	CENTRE POST	DEPTH D		
SB50/6	53	5	6.5	50	600
SB63/6	65	10	6.5	63	400
SB80/6	83	10	6.5	80	280
SB100/6	105	10	6.5	100	320
SB125/6	127	10	6.5	125	200
SB160/6	163	10	6.5	160	80
SB205/6	208	10	6.5	205	65
SB255/6	258	10	6.5	255	80

'DONUT' ADAPTOR RINGS Black LD 18 Foam 7mm thick



'Donut' adaptor rings secure saws with different bore diameters and eliminate movement in transit.

ADAPTOR RING REFERENCE NO.	FOAM DIAMETERS		MINIMUM QUANTITY
	DIAMETER Ø1	DIAMETER Ø2	
DR10/5	10	5	1000
DR13/5	13	5	1000
DR16/10	16	10	1000
DR22/10	22	10	1000
DR25/10	25	10	1000
DR27/10	27	10	1000
DR32/10	32	10	1000

PROTECTIVE SPACERS BLACK Foam 3mm thick

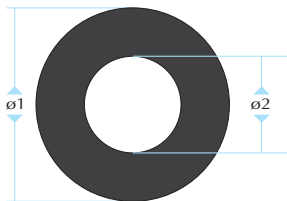

Foam discs increase protection of high cost cutters (e.g. carbide slitting saws) and also act as spacers between saws packed in multiples.

PROTECTIVE SPACER REFERENCE NO.	FOAM DIAMETERS		MINIMUM QUANTITY
	DIAMETER Ø1	DIAMETER Ø2	
PS38/13	38	13	1000
PS50/25	50	25	1000
PS70/32	70	32	1000
PS90/32	90	32	1000
PS125/32	125	32	1000
PS180/32	180	32	1000
PS240/32	240	32	1000



- Custom designed packaging system for slitting and cutting saws.
- Maximum visual impact combined with excellent graphic and labelling capabilities.
- Unique Foam Adaptor Rings and Foam Spacers offer peerless protection.

Plastic labels can be supplied plain or pre-printed to your own requirements

WILLIAM BECKETT
PLASTIC PACKAGING